

### **SmartPad LCD™ 64V:**

The SmartPad LCD 64V includes the same features as the 64G (Graphics version) now with *PiP* and *Full Screen* video display. This version also allows for “Transparent Button” Overlays presenting a clear & seamless integration for video menu device control.

### **Software Note:**

This panel and its features must be accompanied with **Dragon Drop-IR (SPLCD) Version 1.2.0** or above and **Firmware Version 1.29** or above.

### **Checking Software Version:**

To check the software version, open Dragon Drop-IR (SPLCD) and click on the *HELP* Menu and select *ABOUT*. The Software version shall be noted at the top of the pop-up window. If it is not noted or the version does not read 1.2.0 or higher, please see [www.xantech.com](http://www.xantech.com) and download the latest version of Dragon Drop-IR SPLCD.

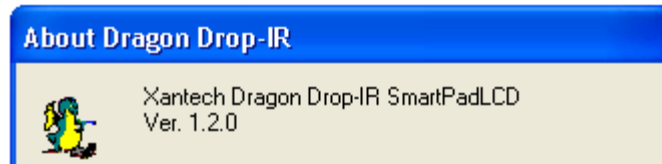

### **Checking Firmware Version:**

To check the SPLCD64V for proper firmware version, connect the panel to the PC running Dragon Drop-IR (SPLCD) and click on the *Base Unit* Menu and select *WHO AM I* from the drop-down menu.

### **Video Connections:**

Connect the composite video signal to the SPLCD 64V via the BNC connection labeled *VIDEO IN* on the rear of the panel.

A buffered composite video signal can also be run *OUT* of the panel to a main Video Monitor in the Zone if desired. To do this, connect a coax cable to the BNC connection labeled *VIDEO OUT* on the rear of the panel.

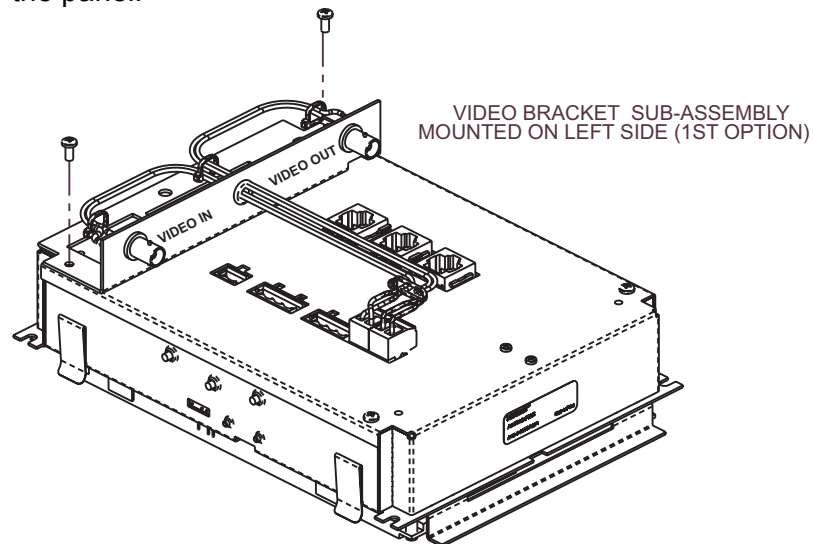

***Picture-In-Picture  
Mode (PiP):***

A PiP window can be opened on any GTL (Graphical Touch Link) Page desired. To enable a PiP:

1. Right-Click on a blank space and select *Enable PiP* from the pop-up menu.

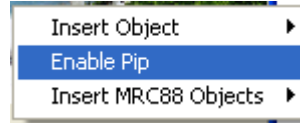

2. Click-&-Hold the *PiP* and Drag to the desired location on the GTL page.
3. To resize the PiP, right-click on the *PiP* and select the desired screen size.

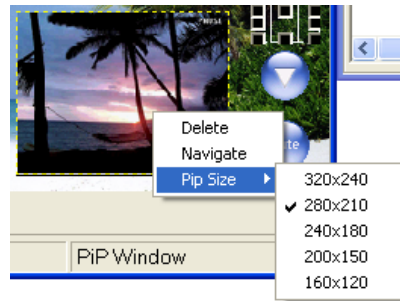
***Enabling Full-  
Screen Video  
Mode:  
To Return to PiP  
Mode:***

Once the project is downloaded to the SPLCD 64V base unit, the *PiP* can be touched to enable *Full Screen* video mode.

Simply touch the middle of the video screen to return back to *PiP* mode.

***Transparent Button  
GTL Overlay  
Feature:***

This feature allows for transparent 'invisible' button GTL to be placed on the video screen during *Full-Screen Video* mode or any screen desired. This is extremely useful for Music Server Control with feedback display on units that output a Video Menu (theme) with buttons imbedded in the video. This is also useful for *hiding* Volume UP & DOWN or Channel UP & DOWN functionality to be available even when in Full-Screen Video mode.

For Full Screen Transparent Button Overlay Functionality:

1. Right-click on the PiP screen and select *NAVIGATE* from the pop-up menu.

**Note:** A Full Screen page will appear with a transparent button object displayed in the middle. This object is the *Return to PiP* button and cannot be removed. This button can be resized and moved to any desired location.

2. To add a *Transparent Button GTL* simply right-click anywhere on the blank area of the screen and select *Insert Object* from the pop-up menu.

3. Select *Insert Transparent Button* from the pop-up menu. A Transparent Button will appear outlined on the screen.
4. Click-and-drag the button to the desired location (must be in GRAPHICS Mode)
5. The button can be re-sized easily by clicking on one of the blue squares outlining the button and dragging the square to the desired size.

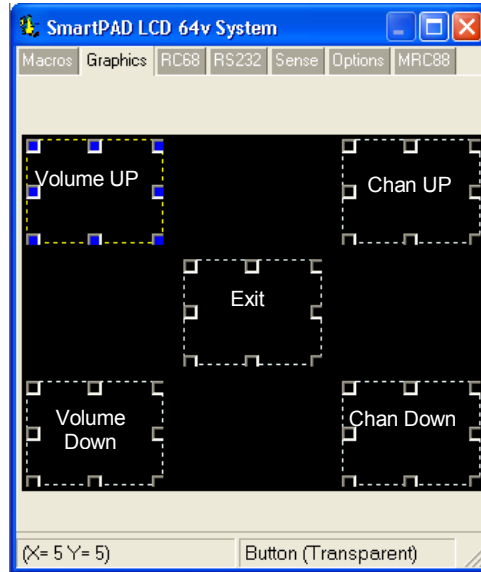

6. After all desired buttons are placed and sized appropriately on the PiP Video screen, you can now assign IR and/or RS232 Macro's to these buttons in the same manner as a standard GTL. (I.e. Assign top right and bottom right buttons as Channel UP/Down or Volume UP/DOWN.)

### ***Transparent Button GTL Music Server Integration:***

To interface to a Music Server Video Menu Screen (or any other products Video Menu Screen), follow the steps below. If the product interfacing to has a BMP (bitmap) file for reference, you can display this image in the software and *drag and drop* transparent buttons over it for seamless control of the device.:

1. Right-click on the PiP screen and select *NAVIGATE* from the pop-up menu.

**Note:** A Full Screen page will appear with a transparent button object displayed in the middle. This object is the *Return to PiP* button and cannot be removed. This button can be resized and moved to any desired location.

2. Right-Click anywhere on the blank area of the screen and select *Add Video Image Template* from the pop-up menu.

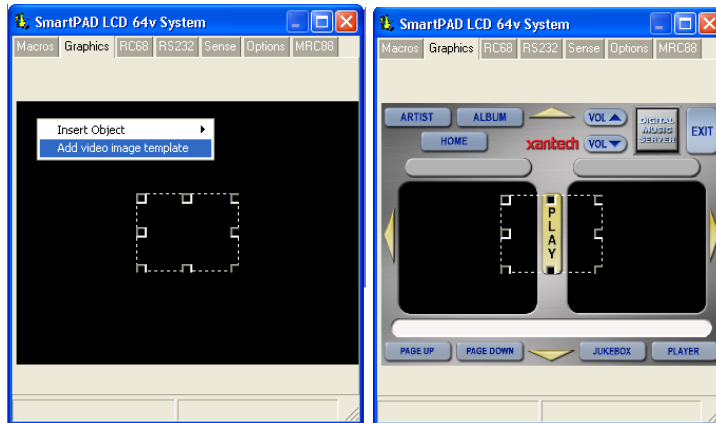

3. Select the BMP image that represents the video menu to display.
4. Follow steps 3 thru 6 as displayed above to add Transparent GTL's to the template PiP and assign functionality to the GTL's.

### ***Other Uses for Transparent GTL's:***

The transparent GTL feature is available for use on ALL versions of the SmartPad LCD™ Controllers (SPLCD39G, 57G, 64G, and 64V). Transparent GTL's can be placed anywhere over an object such as a picture used as a backdrop, Volume Bars etc...

See the example below illustrating how Transparent GTL buttons can be placed over areas of a custom background for realistic visual functionality:

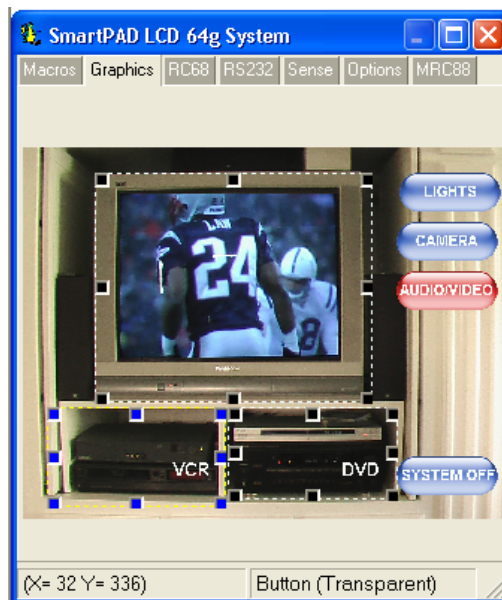

**Note:** Please see section on IMPORTING BACKGROUNDS for instructions. After the desired background is placed on the SmartPad LCD™ Systems window, place Source buttons as you would normally

and then follow the instructions below for adding Transparent Button GTL's:

1. To add a *Transparent Button GTL* simply right-click anywhere on the blank area of the screen and select *Insert Object* from the pop-up menu.
2. Select *Insert Transparent Button* from the pop-up menu. A Transparent Button will appear outlined on the screen.
3. Click-and-drag the button to the desired location.
4. The button can be re-sized easily by clicking on one of the blue squares outlining the button and dragging the square to the desired size.

---

***MRC88/SmartPad™  
LCD Emulation  
Mode:***

The full line of SmartPad™ LCD Controllers can be seamlessly integrated into a new or existing MRC88 System over the standard CAT5 cable. This allows the SmartPad LCD™ Controller to access any macro programmed in the MRC88 Controller without the use of IR commands. All Macro Programming resides in the MRC88 allowing for ease of initial programming and any upgrades that should occur.

***Connecting the  
SPLCD to the  
MRC88 Controller:***

1. Connect one end of the CAT5 to the **Keypad** port on the rear of the MRC88 Controller and the other end to the **Controller** port on the rear of the SPLCD Panel.
2. 16vDC Power must still be run directly to the +16VDC and GND Terminals on the rear of the SPLCD panel.

**Note: The SPLCD cannot be powered directly from the MRC88 Controller.**

3. If using multiple keypads in a single Zone, the last keypad in line must have the Zone Termination Jumper installed.

**Note: The SPLCD comes with the Zone Termination Jumper installed by default.**

***Configuring  
Dragon Drop SPLCD  
for MRC88  
Emulation Mode:***

1. Program the MRC88 as you would for a standard MRC88 Keypad using both the Tier1 and Tier2 of the buttons for added functionality.
2. Create the graphic layout for an SPLCD project in Dragon as you would normally.
3. After all of the GTL's are layed out as in a standard SPLCD project, click on the TAB labeled **MRC88** in the SPLCD Systems Window.
4. Check the box labeled **Emulate MRC88 Keypad**
5. If you are using Multiple Keypads in a single zone, set each keypad to a unique **Keypad Address**. Up to four keypads can be used together in a single zone. **Note:** If using standard MRC88 Keypads in conjunction with the SPLCD in the Zone, you must set the MRC88KP Address Jumper to the specific address.
6. Under **MRC88 Source Names** enter the names as they appear in the MRC88 Software. **Note:** This is necessary for proper Source Name display when using the MRC88 **STATUS** function.

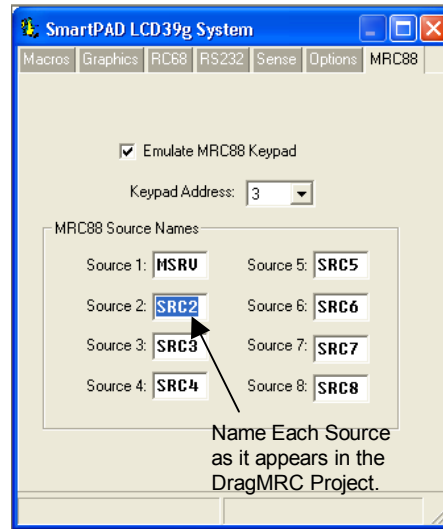

### ***Programming SPLCD for MRC88 Functionality:***

Once Dragon Drop SPLCD is configured for MRC88 Keypad Emulation, you can now point each GTL on the SmartPad LCD™ to a specific macro within the MRC88 Controller.

1. Click on the MACROS Tab to lock in the current GTL button layout.
2. Select a Source Button in the SPLCD Systems Window.
3. Click on the PALETTES menu and select **Internal Commands** from the drop-down menu.
4. Click on **Backlight Set** in the Internal Command Window and select MRC88 Button Id from the drop-down menu.

These are pointers to buttons within the MRC88 Controller.

Whatever Macro is programmed within the MRC88 under these buttons, the SPLCD can now execute these Macro's.

5. Scroll through the list and associate SPLCD buttons to Macros programmed under specific buttons within the MRC88 Controller. i.e. Click on a Source Button and then select **Src 1** from the MRC88 Button Id list as in the example below.

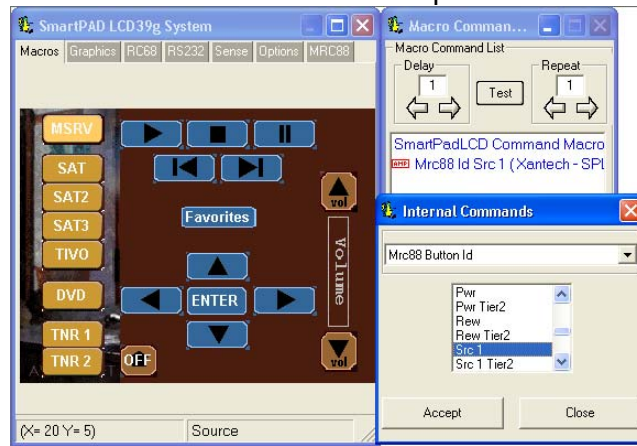



6. Repeat above for all of the Source Buttons.
7. Repeat the same procedure for PLAY STOP PAUSE etc.....
8. You can even assign SPLCD GTL Buttons to an MRC88 Tier 2 Macro. For example: Assign the 5 Motion control buttons to as Tier 1 PLAY STOP PAUSE etc... In your MRC88 Project program Tier 2 of the PLAY STOP PAUSE etc.. buttons as MENU Navigation buttons and now select a SPLCD Button for ENTER and assign it the PLAY TIER 2 Button Id.
9. Continue this for all buttons on the SPLCD (i.e. MRC88 Volume Up, Down OFF MUTE etc....) that you want to control the MRC88.
10. If more button control is needed from the SPLCD you can still program standard buttons to pass IR through the CAT5 and MRC88 Controller as you would in a standard project. For Macro functionality, use RC68 IR Trigger codes within the MRC88 Software. Therefore the SPLCD only needs to send a single IR command to trigger a long macro within the MRC88. This keeps all of the Macro programming within the MRC88.

***Placing MRC88  
Objects on the  
SPLCD:***

You can also place MRC88 graphic objects on the page. Objects that can be displayed are as follows:

- **STATUS** Display: Displays Zone Status, Source Icons, and Zone Linking information from the MRC88
- **INFORMATION** Display: **Xantech XDT Tuner** Feedback display, MUTE and ZONE OFF status, Priority Lockout, etc.
- **Horizontal Bars**: Horizontal bar for Volume display or EQ/Balance level display
- **Vertical Bars**: Vertical Bar for Volume display or EQ/Balance display.

To display one or more of these objects,

1. Right-click on a blank area of the background.
2. Select **Insert MRC88 Object** from the drop-down menu.
3. Choose from Horizontal or Vertical Volume, EQ/Balance bars, Informational Display, or Status Display.

**Note:** Once placed on the SPLCD Systems window, these objects can be moved to any desired location and the border colors can be modified to fit the desired style.

Horizontal and Vertical Bars can be resized for length and width. STATUS and INFORMATION displays cannot be resized.

---

***Transparent GTL's  
and MRC88  
Emulation:***

Combining these two features allows for unique programming possibilities.

Below is an example for creating Interactive Volume Bars so the user can press different areas of the Volume bar and have the Zone Volume Level *jump* immediately to that level. In this particular example we will





## Configuring SPLCD in Dragon Drop-IR SPLCD:

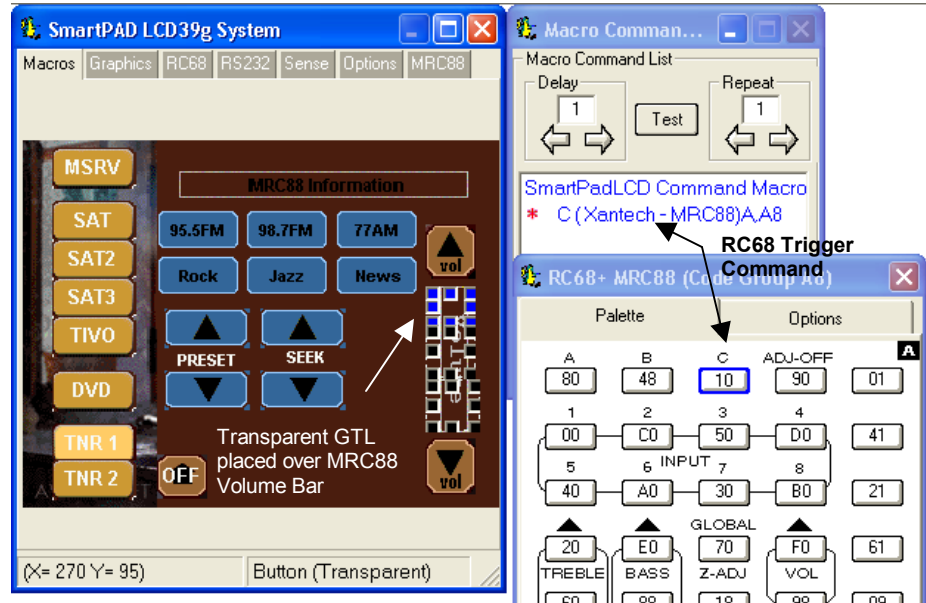

### Placing the Volume Bar:

1. Right-click on a blank area of the background and select **Insert MRC88 Object** from the drop-down menu.
2. Choose from Horizontal or Vertical Volume bar.
3. Place and resize to desired position.

### Creating Transparent GTL's over Volume Bar:

1. Right-Click on a blank area of the background and select Insert Object – Insert Transparent Button from the drop-down menu.
2. Resize the box to cover 1/3 of the volume bar and place over the bottom 1/3 of the Volume Bar.
3. Place 2 more Transparent GTL boxes over the middle and upper 1/3 of the section of the Volume Bar

### Assigning the Proper RC68 IR Codes to the Transparent GTL's

1. Click on Palettes and select RC68 Command Palette from the menu.
2. Click on the OPTIONS Tab on the Virtual RC68 Palette and choose MRC88 from the Xantech Model drop-down menu.
3. Click on the PALETTE Tab on the Virtual RC68
4. On the SPLCD Systems window, select the Transparent GTL placed on the lower 1/3 of the Volume Bar.
5. Select the [80] button from the Virtual RC68 Palette (under the Command List Window you should see the command 'A(Xantech-MRC88)A,A8' )
6. Repeat steps 4 and 5 for the Middle and Hi level Transparent GTL with the RC68 [48] and [10] commands as shown above.

***Importing Pictures  
as Custom  
Backgrounds:***

This is easiest performed on the SPLCD64G and SPLCD64V units due to increased screen resolution (640x480).

Use the following guide lines when importing user-defined Bitmap images,:

1. The image must be sized to 640x480 pixel resolution.
2. **The image must be saved as a 16Bit 64k color Bitmap Image.**
3. Place the image into the desired Style Background folder

**Note:** Background Style Directories are located at C:\Program Files\Xantech\Dragon Drop-IR(SPLCD)\Icons\SPLCD folder as shown below.

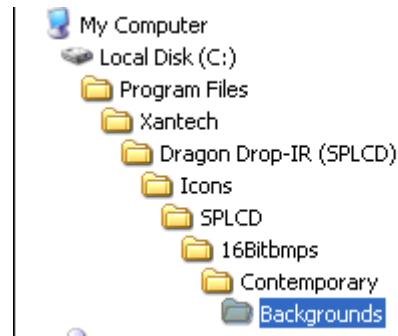

4. Re-start Dragon Drop-IR (SPLCD) software and select the Style imported to and click on the Backgrounds folder and you should see the imported background.